



From Ounces to Tons
 No job too big or too small

390 Millen Road, Rear Unit, Stoney Creek, Ontario, L8E 2P7

Toll free 866-979-7911 Phone 905 662 9143 Fax 905 385 2614

Email: info@alchemyextrusions.com

Heater Treater Anodes

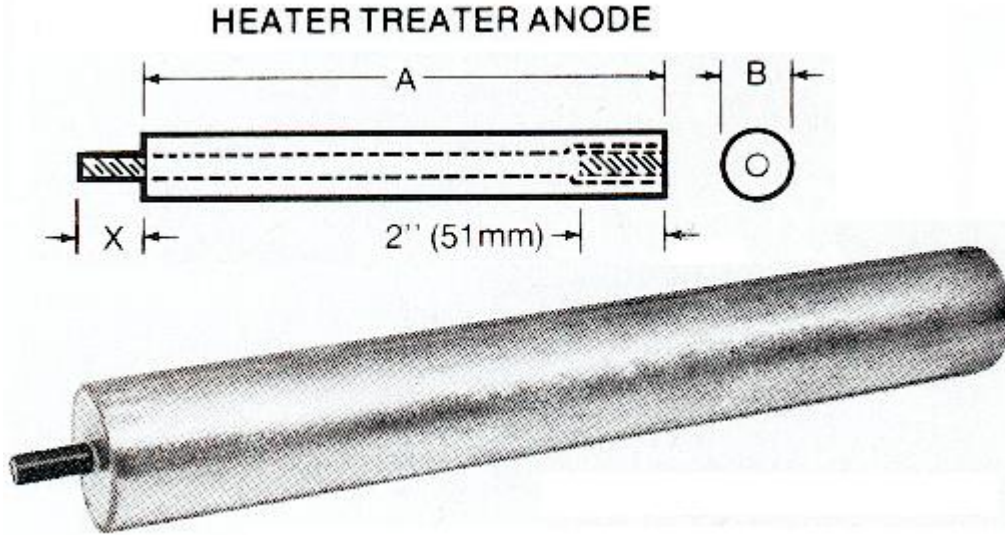

PART No.	Weight (Lbs)	A	B	X	MOUNTING
Treater Z321	39	21.5"	3.0"	1.0, 1.5"	Threaded
Treater Z321A	39	21.5"	3.0"	4.0"	Threaded
Treater Z330	56	30.0"	3.0"	1.0, 1.5"	Threaded
Treater Z330A	56	4.0"	1.25"	4.0"	Threaded

Types 321 & 321A use 0.625" NF rod. Types 330 & 330A use 0.75" NC rod. Other rod sizes and extended lengths may be specified by purchaser.